

> Pre-installation reference guide

Toroid underground tanks >

©The patent and copyright are the property of Viscount Rotational Mouldings Pty. Ltd, and may not be reproduced without the written permission of Viscount Rotational Mouldings Pty. Ltd.
AU Patent No. 2006202525
NZ Patent No. 332747
US Patent No. 11/424, 108

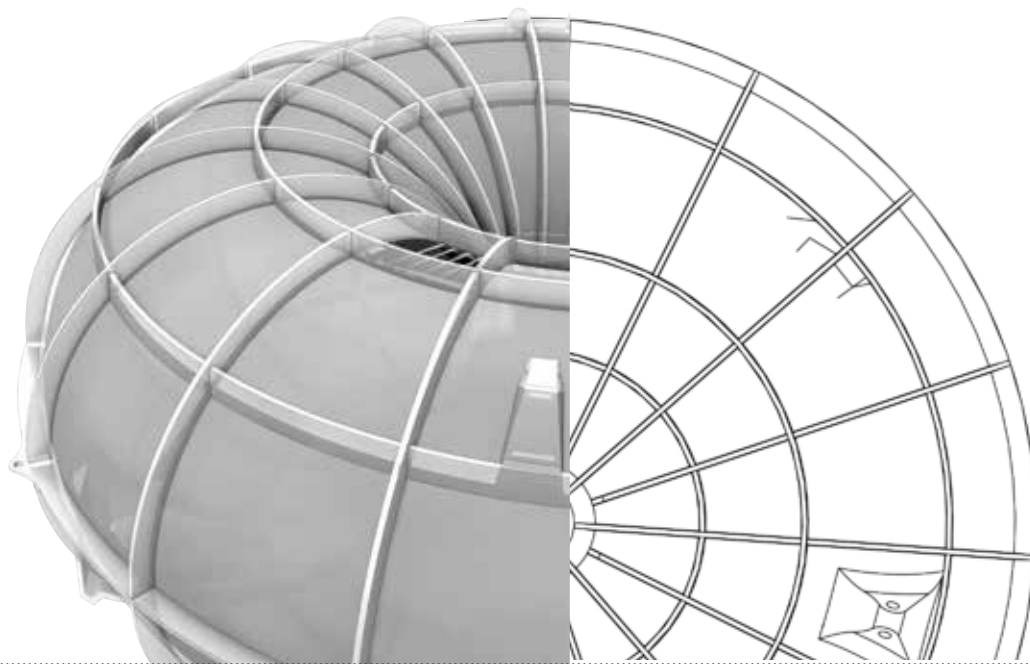

Viscount Rotational Mouldings Pty Ltd

ABN: 19067462337

81 Frankston Gardens Drive
Carrum Downs, Victoria, 3201, Australia.

Tel: (03) 8770 3200

Fax: (03) 8770 3204

Sales Enquiries: 1800 775 000

Web VRM: www.viscountroto.com.au

Index

Tank Specifications	02 - 03
Maintenance & Warranty	04
Before you Dig / Site Excavation	05 - 06
Compression Ballast	07
Base, Backfill & Topdressing	08
Standard Tank Fit Out & Fittings	09
Multiple Tank Installation	10
Retention / Detention	11
Accessories	12 - 13
Tank Volume & Depth	14
Step by Step Photographs	15



Key

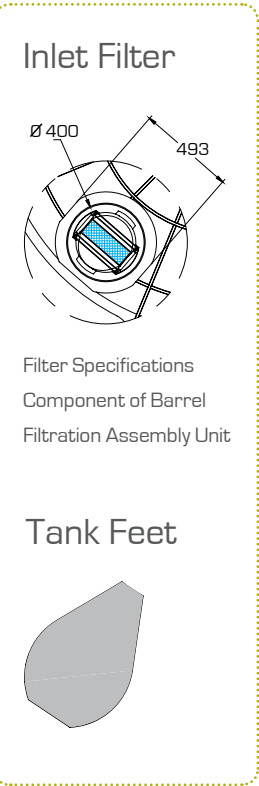

Tank Specification

3,000L Donut

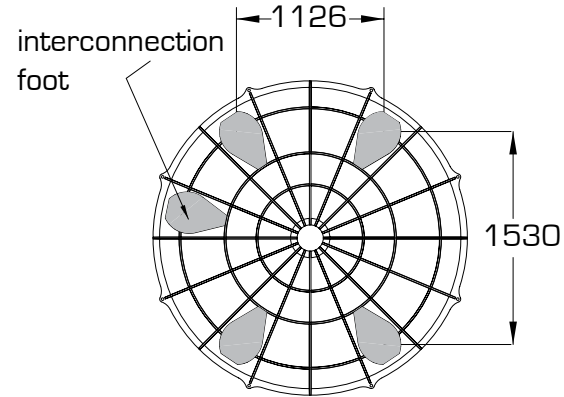
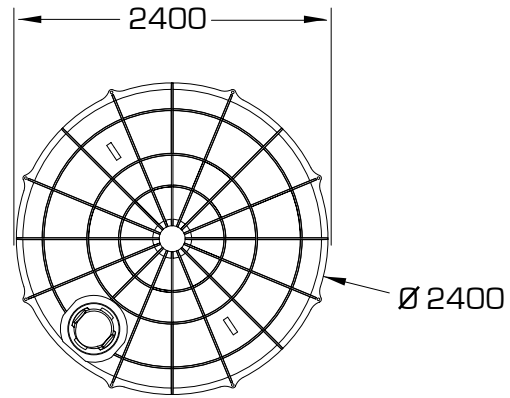

5th Foot with moulded in 100mm
BSP threaded interconnect.

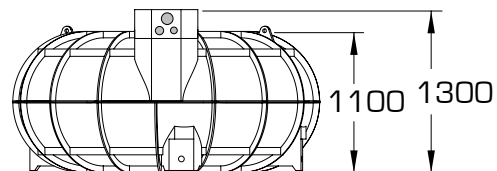

5,000L Bagel

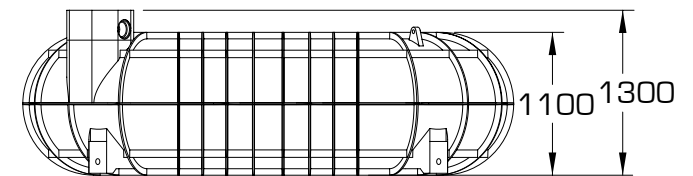
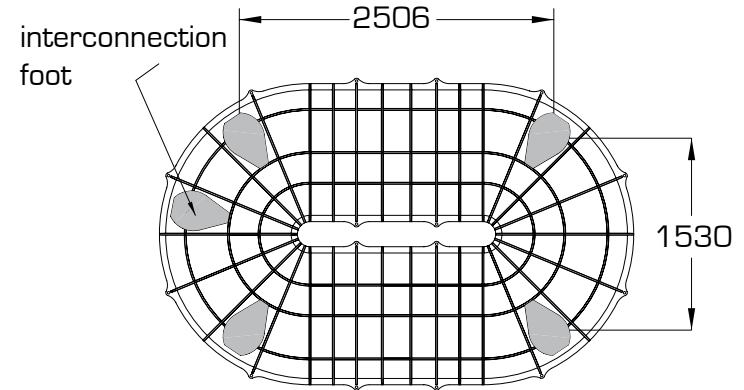
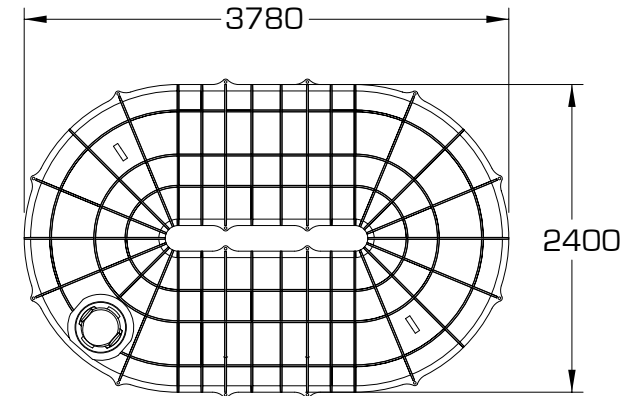

Maintenance & Warranty

This is a summary of the warranty only.

Full warranty details are available by contacting VRM on: 1800 775 000 or online at www.tankmasta.com.au

Care & Maintenance

All water tanks are low maintenance not no maintenance. VRM's flow-through barrel filters mean that our undergrounds are very low in maintenance.

However VRM recommends that all tank installations include a maintenance program based on local conditions.

If deemed necessary, the quantity of fine particles entering the tank can be reduced by installing a first flush or continuous diverter. Another option is to install an in-line cartridge filter after the pump which will remove particles and impurities from the water. This option can be of particular benefit if the water is being used in household appliances.

With even the most basic maintenance program, your underground tank should provide you with decades of trouble free service.

Underground Tank Warranty

Toroid underground water storage tanks are warranted for a period of seven years against faulty workmanship and/or material fault, providing the installation instructions supplied are adhered to by a licensed plumber.

Underground installations are subject to a range of conditions that vary from site to site. As a result we recommend that all installations be independently assessed by a suitably qualified person to establish how best to approach the unique features of the installation site. Compliance with local authority regulations, application for planning permits, correct site preparation, determination of soil type, water table data and providing a safe working environment for the installation of Toroid underground tanks, is the sole responsibility of the installer.

As all Toroids are pressure tested prior to leaving the factory, it is critically important that all connections be installed as per this 'pre-installation reference guide.'

All plumbing works are the responsibility of the installer.

Summary of Conditions:

- 1) Viscount Rotational Mouldings (VRM) warrants that it's tanks are free from defects caused by faulty material and/or workmanship during the manufacture of the tank.
- 2) Viscount Rotational Mouldings warrants that it's tanks will be fit for the purpose for which they were designed, namely storing rain/storm water, for a period of seven years from the date of purchase.
- 3) This warranty will not apply where:
 - Where damage to the tank or property is caused during the installation process or before the installation has been completed. i.e. Connection of inlet and overflow.
 - The tank is damaged on site or during any movement or relocation.
 - The installation guidelines are not followed or inadequate site evaluation is conducted.
 - Where the tank is installed by an unqualified/non accredited installer.
 - Proof of purchase or the tanks serial number cannot be substantiated.
 - The serial number has been deliberately defaced or removed.

Before you Dig

Your Installation

A case by case site assessment by a suitably qualified engineer is recommended for every installation. Often underground tanks are installed before they are actually connected to a catchment area and issues such as storm water run-off before any water can enter the tanks is easily overlooked.

The installation of any underground tank must be performed by a licensed plumber who is capable of conducting an adequate site assessment and is fully aware of their requirements and obligations under Federal, State and Local authorities regulations regarding the following issues.

Occupational Health and Safety:

It is the installer's responsibility to ensure a safe working environment is provided throughout the installation of a Toroid underground.

Proximity of:

Underground services i.e. gas, electricity, water, sewer, cables.

Proximity to:

Existing buildings, foundations, and/or areas of influence.

Lifting tank into position:

Tanks should be lifted by the two lifting lugs located at the top of the tank body.

Nature of the ground:

Soil / rock type, moisture content, water table, faults & bedding planes.

Excavation Guidelines and Requirements:

The contractor undertaking the excavation must be aware of the governing regulations concerning the angle of repose and the area & zones of influence.

Environment

Issues such as traffic on and around the excavated site, storm water run-off before the tank is connected to a catchment area, even tidal effluences need to be considered.

Site Excavation

Load & Non Load Bearing:

Since their launch in 2005, VRM's Toroid undergrounds have been installed in wet and dry soil situations.

The only difference between these methods of installation is the calculation of the ballast requirements to prevent hydrostatic lift.

In layman's terms, every litre of the tanks capacity will equal 1kg of upward force if an empty tank comes into contact with water. A 3,000lt Donut will need at least 3001kg of ballast and a 5,000lt Bagel will require at least 5001kg of ballast to stop a tank from floating if it comes in contact with water.

Ballast calculations can include the weight of the tank and any other matter that will combine to achieve greater downward pressure (positive ballast) than water can apply to an empty tank. Water can be used to stabilise a tank during the installation process, but ballast calculation should always assume a worst case situation of the tank being empty of all water.

Excavation:

Tank and Barrel Filter Assembly:	+ 1300mm
Base*:	+ 100mm
<hr/>	
Depth:	1400mm [Approximate]

*Either blue metal (max 10mm grade) or 3% stabilised sand should be used to provide a stable base. If the site has been over excavated either of these products should be used to establish the required height of the excavation. It is recommended that a 1% fall be created in the base in the direction of the inlet to allow any sediment to collect at this point to provide easy maintenance of the tank.

As a general rule an excavation should be 200mm greater than the length and width of the tank being installed (listed below) This will change depending on the soil type being excavated and is subject to individual site assessment.

Tank Dimensions:

3000lt Donut:

Length: 2400mm
Width: 2400mm
Height: 1300mm *

5000lt Bagel:

Length: 3780mm
Width: 2400mm
Height: 1300mm *

*Height of tanks is including
Barrel Filter Assembly.



Compression Ballast

WARNING: If there is to be a delay in connecting an inlet/overflow pipe to the tank, precaution must be taken to stop storm-water from entering the excavated site or the appropriate ballast should be applied to negate the possibility of storm-water creating hydrostatic lift on the empty tank. The full blast load must be used on the tank itself.

VRM's patented 'Compression Ballast' installation technique is only required if the tank will come in contact with ground water effecting the excavated site. Compression Ballast is applied as a dead weight on top of the tank, creating a dead weight that will never deteriorate or separate over time.

Whether an installation requires ballast is the most contentious issue of any underground installation. We have examples of calculations for ballast for a 5000lt Bagel ranging from no ballast to a requirement of 2.3 cubic meters of concrete. Our guidelines are designed to achieve a workable blend between enough ballast to prevent hydrostatic lift and the commercial realities of time and cost. Our recommendations are based on the assumption that:

- The site is level.
- That the installation will be completed in a single day.
Note: including the plumbing of the inlet and overflow.
- That the installation will be conducted during fine weather.
- That the excavation will be approximately 1.5 metres deep.
- That the base and backfill will be as per these guidelines.
- The hydrostatic pressure will be created by a rising water table under the tank.

If the installation being conducted differs from these assumptions we would recommend that your ballast requirement be calculated by a suitable qualified engineer using the requirements stated in the Australian Building Code – section 10b.

Compression Ballast Guidelines:

3000lt Donut

1.4m³ of 20-25mps slump concrete

- net weight of concrete : 3140kg
- not including the weight of the tank or topdressing

5000lt Bagel

2.3m³ of 20-25mps slump concrete

- net weight of concrete : 5159kg
- not including the weight of the tank or topdressing

Note: Calculations based on below figures:

Concrete dry weight:
Specific gravity of 2.243
2243Kg per m³

Base, Backfill & Topdressing

Base: (see site excavation)

100mm of either blue metal (max 10mm grade) or 3% stabilised sand.

Backfill:

VRM's recommends three types of backfill only;

For 'dry' installations – where the tanks will not be affected by ground water.

Maximum of 10mm recycled blue metal or 3% minimum concrete stabilised sand backfilled to the top of the tank.

For 'wet' installations where water table, ground or storm water will affect the excavated site

Minimum 3% concrete stabilised sand or crushed rock, 20mm grade backfilled to the top of the tank.

Compression Ballast requirement (poured on top of the tank):

3000lt Donut:

1.4m³ of 20-25mps 80 slump concrete

5000lt Bagel:

2.3m³ of 20-25mps 80 slump concrete

Topdressing:

Non-Load Bearing

Excavated soil (clean fill with no rock particles greater than 20mm)

Load Bearing:

Load bearing installations should utilise a structural heavy duty lid and collar combination. Alternatively a structural steel lid can be used separating the vertical load from the standard lid, collar and tank assembly. It is critical that any load greater than 500 kg is not transferred to the actual tank itself but to the surrounding concrete floor or driveway by using a steel ring (refer to page 13).



Standard Tank Fit Out & Fittings

Barrel Filter Assembly

Barrel Filter Assembly supplied separately to tank.

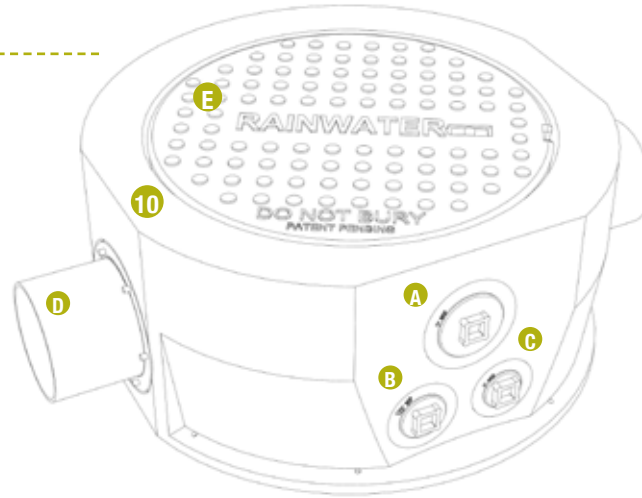
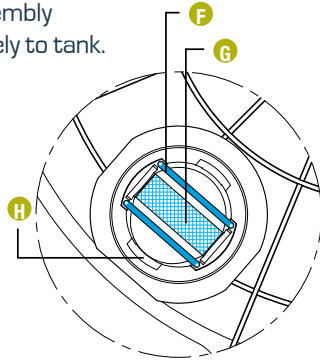

Barrel Filtration Assembly:

- A 50mm female thread - suitable for an electrical cable with a standard electrical plug fitted.
- B 32mm female thread - suitable for water outlet.
- C 25mm female thread - suitable for water inlet for top up system or air vent between inter connected tanks.
- D 100mm spinweld fitting (x 2) - used for rainwater inlet & tank overflow.
- E Lockable Lid
- F 2 x child safety bars
- G 1 x 100mm Barrel filter
- H 2 x flat catch plates for lockable lid

Standard Outlet Fit-out

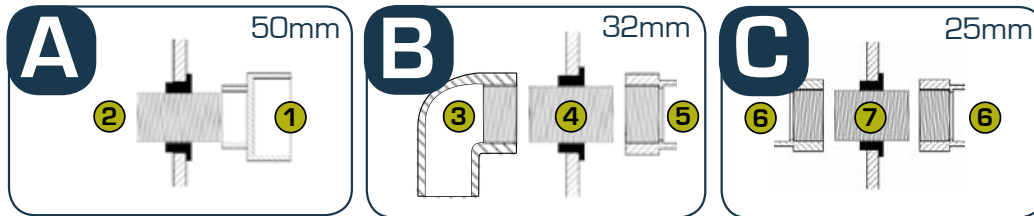

Fittings sold separately

Installation of Barrel Filtration Assembly Unit

Fittings for Tank:

Please note: Tankmasta do not sell the below items, however they are readily available from your local plumbing store.

- A 1 50mm PVC Socket
- 2 50mm threaded pipe (Poly or Brass)
- B 3 32mm PVC threaded elbow
- 4 32mm threaded pipe (Poly or Brass)
- 5 32mm PVC Faucet Socket
- C 6 25mm PVC Faucet Socket
- 7 25mm threaded pipe (Poly or Brass)

Installation of Barrel Filtration Assembly Unit

- 1 & 2 Apply silicone to surface of tank that is to be connected to neck
- 3 Fit neck into place, apply even pressure to bind silicone. Note: Neck can be fitted at any angle to best suit your plumbing requirements.
- 4 Pre-drill holes for screws with 3mm drill bit.
- 5 Drill in self-tapping T17 hex head 50mm screws (8 supplied).

Multiple Tank Installation

Fitting a 50mm Tank Outlet

1. Using a 64-67mm holesaw on the drill point location on the foot, drill and deburr the hole removing any plastic shavings that may have entered the tank.
2. Unscrew the 50mm Tank Outlet and front seal.
3. Install the 50mm Tank Outlet using a rope from the manhole to the outlet hole.
4. Pull the fitting through the hole and attach firstly the seal and then the locking nut. Tighten the locking nut using a spanner or similar to ensure a water tight seal.

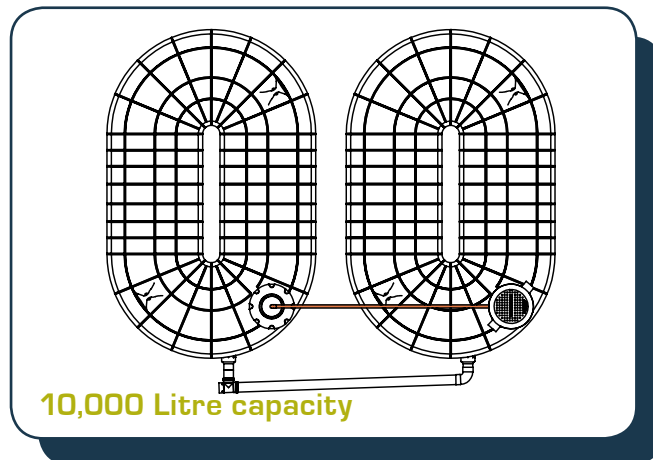
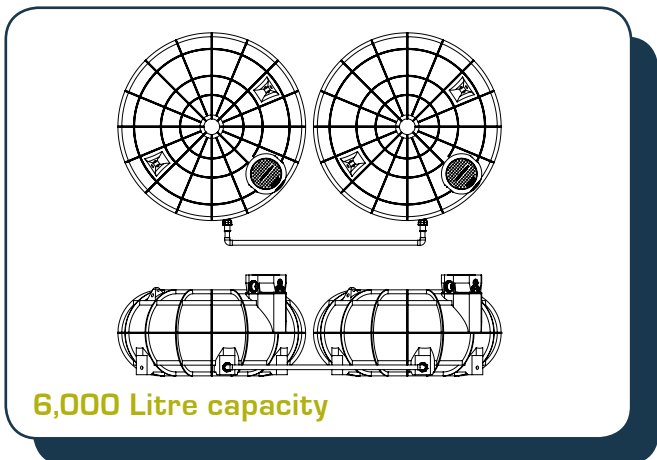
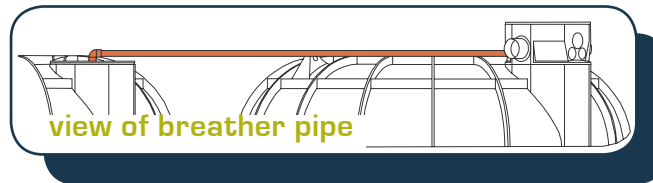
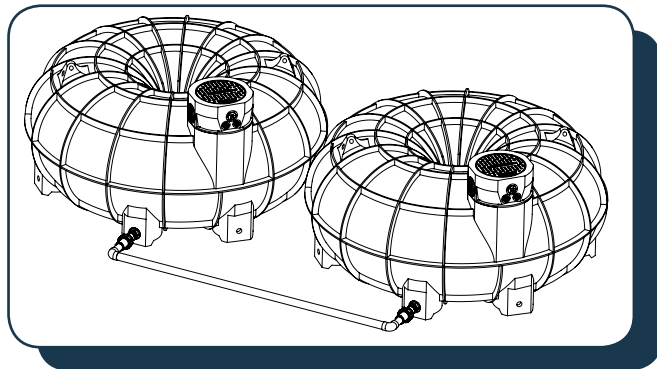

Multiple Tank Configurations

The donut and bagel undergrounds can be coupled together in any combination to achieve greater capacities.

When interconnecting tanks it is critical to use a 50mm coupling and swivel joint close to the tank to absorb any ground movement that may create pressure / uneven loading on the pipe work. Before commencing the backfill, it is important to ensure that any exposed pipe work is fully supported to prevent damage.

Note: It is highly recommended that whenever the interconnection fitting is used the tank be water tested before you commence the backfill. All Toroids are pressure tested for leaks before they leave the factory, so if a leak occurs at this location it will be the responsibility of the installer to rectify.

Retention / Detention



50mm PVC BSP Tank Outlet

Fit a 50mm BSP Tank Outlet in the interconnection foot. Refer to images on previous page under title 'Fitting a 50mm BSP Tank Outlet.' Please Note Option to have 100mm interconnection piping is available if required.



50mm PVC BSP coupling

Fit a 50mm PVC BSP coupling to the Tank Outlet (use teflon tape).



50mm PVC Swivel Joint

It is critical that a 50mm swivel joint be placed close to the tank to absorb any ground pressure exerted onto the pipe work. Using a swivel joint will minimize uneven loading on the tank fittings.



Backflow Prevention Unit

Placed in the tanks overflow, a backflow prevention valve will stop storm water back flowing into the tank.

Note: All above fittings sold separately

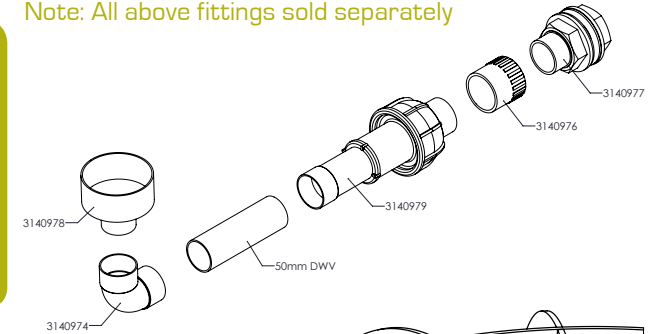

Toroid undergrounds can be easily adapted to create a retention / detention system.

By adjusting the external overflow pipe work to the height of desired capacity to be stored in the tank (retention) and simply drilling the required discharge hole size in the interconnect foot, a storm water detention system can be created. It is important that any retention / detention system include a 50mm swivel coupling at the interconnection foot and a storm water backflow prevention valve.

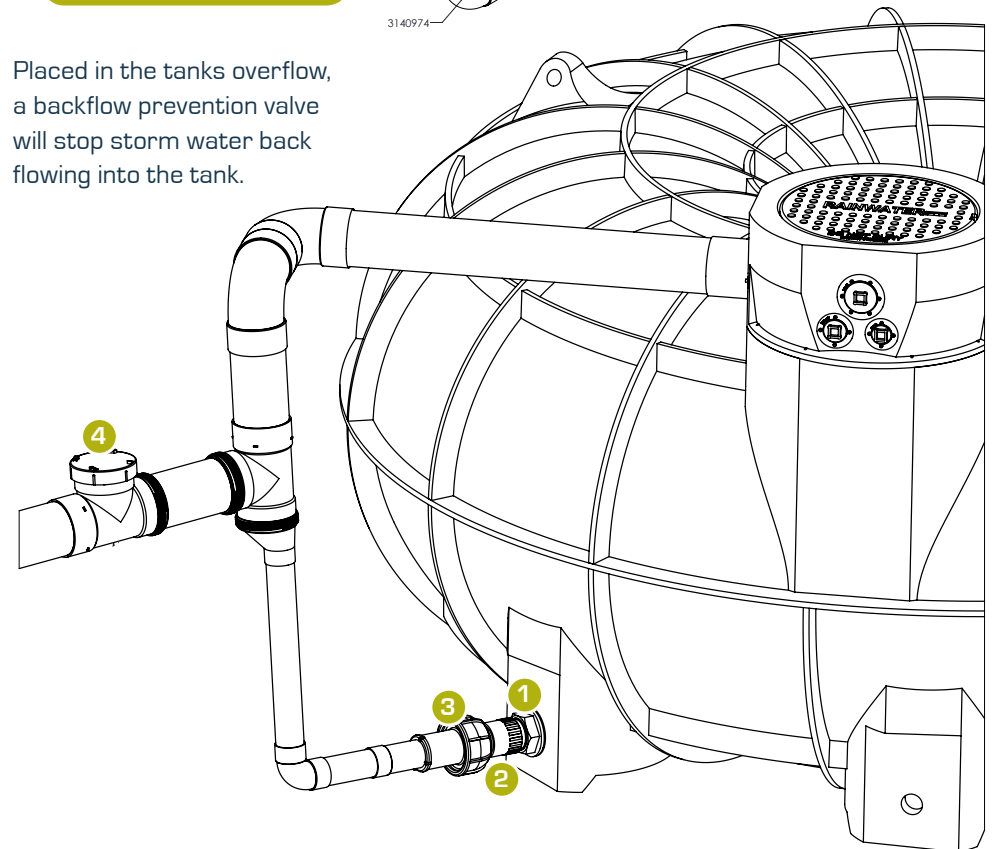

Accessories

Foam Filled Adjustable Collar & Lid

As an optional extra VRM can supply a foam filled collar, lid and steel ring for installations in vehicle traffic zones (Refer to page 13).

Cone Riser Instructions

The cone riser allows the tank to be installed without knowing the final site level. Work can continue around the site and the final adjustments can be made after all site work is complete. The cone riser can also be installed to raise the tank inlet height e.g.

- To install the tank at the depth of the existing pipe work.
- When the tank inlet is situated in a raised garden bed.

The smooth wall surface allows for electrical inlet fittings to be installed into the cone riser providing easier access closer to the grounds surface.

Note: Maximum height adjustment is 600mm.

The cone riser is an optional extra and does not come standard.

Fitting Collar / Riser to Barrel Filter Assembly

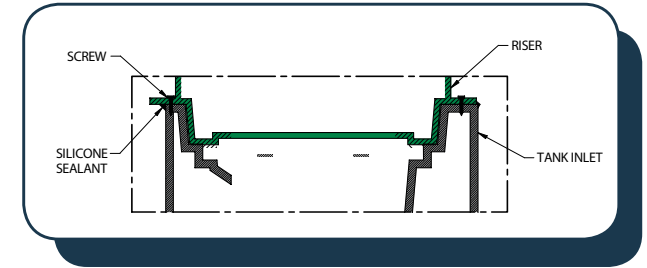
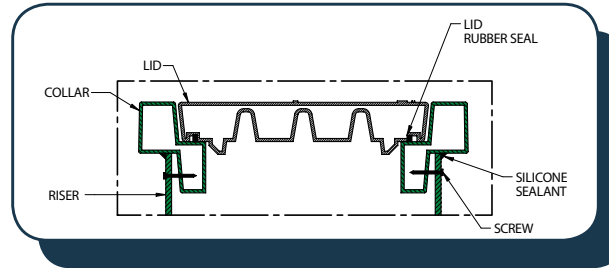

Interconnect System / Typical Installation:

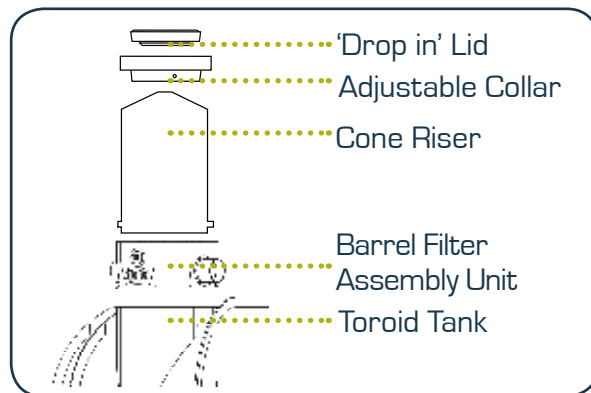
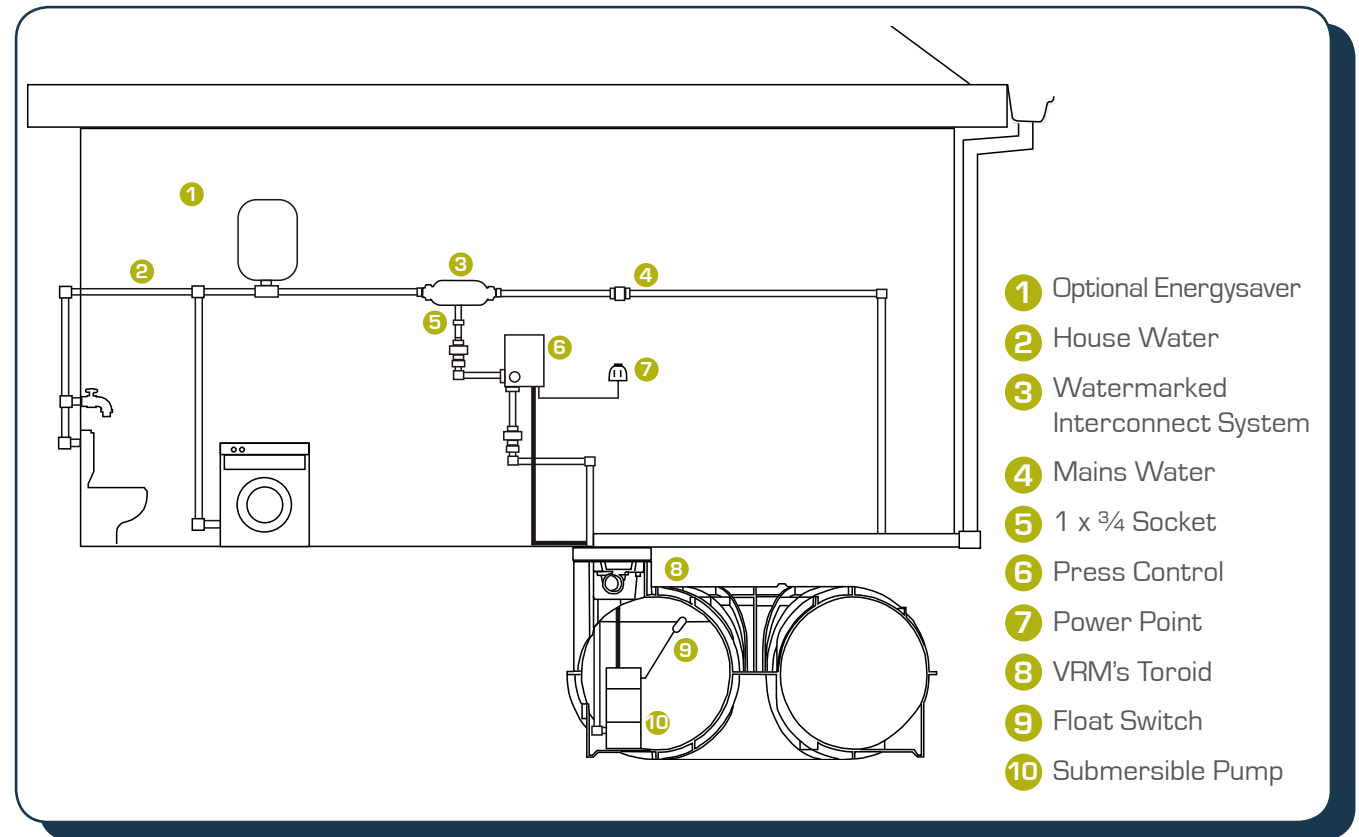

Accessories for Tanks Installed in Vehicle Traffic Zones

Foot Traffic Only

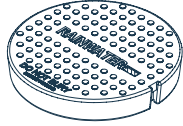

Lid Standard Lockable

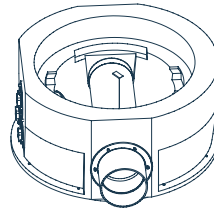

Barrel Filter Assembly

Heavy Duty Option A

Please Note: When riser is not used, the steel ring must be used to support the collar in the concrete.

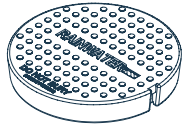

Lid Foam Filled
(Heavy Duty) Lockable

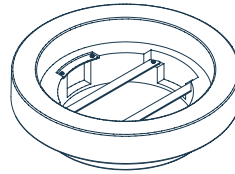

Collar Foam Filled

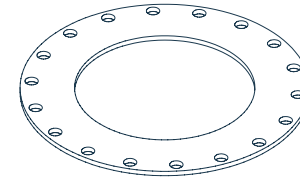

Laser Cut 12mm Mild Seal Ring

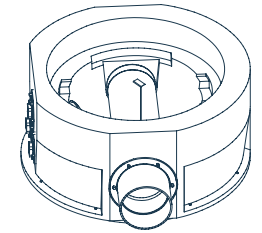

Barrel Filter Assembly

Heavy Duty Option B

Example of installation using reinforced concrete and riser (no steel ring required)

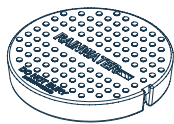
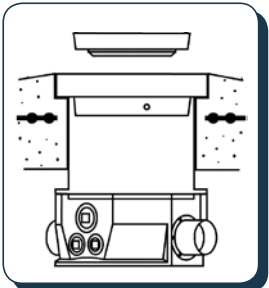

Lid Foam (Heavy Duty)
Lockable

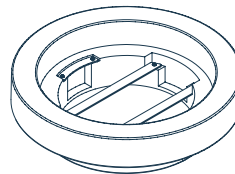

Collar Foam Filled

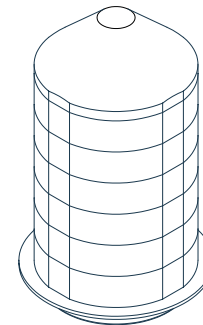

Cone Riser

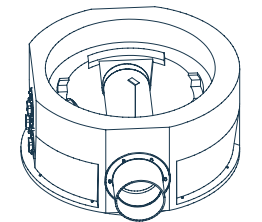

Barrel Filter Assembly

Tank Volumes

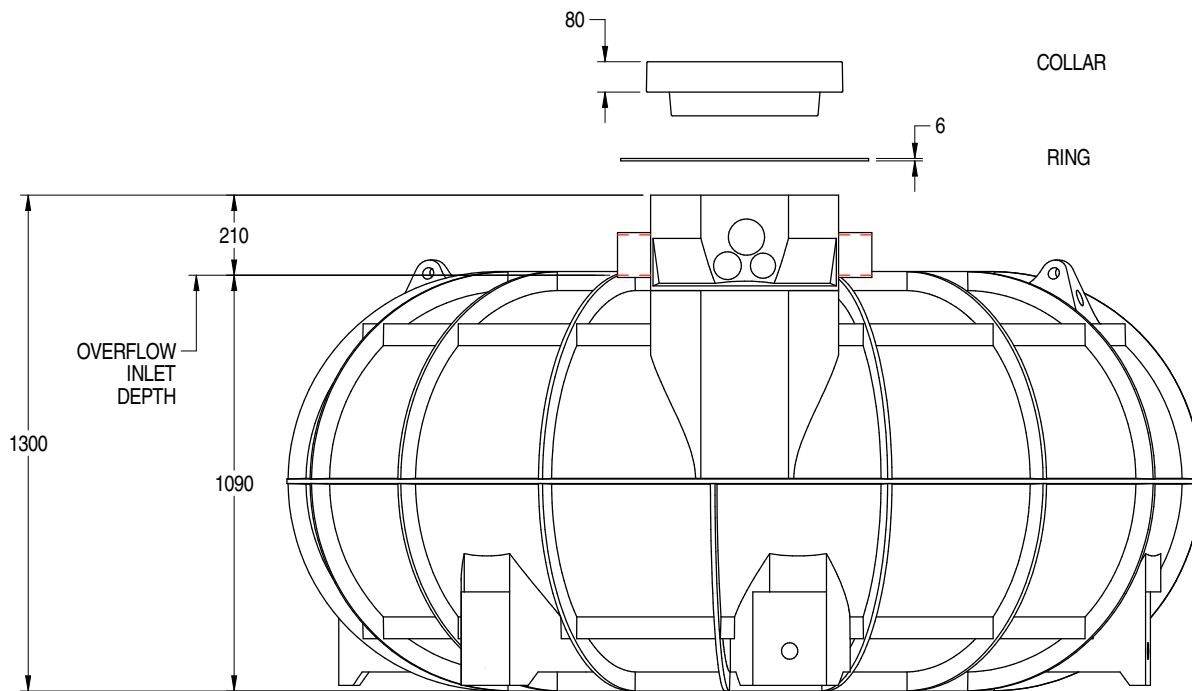

This table and diagram indicate the volume of water in the tank at specific depths. This information can be used to determine the position of the float switch where a mains top up or interconnect system is fitted to the tank or for retention detention systems.

Measurements are approximate.

Depth from Top Inlet	% of Volume	Volume	
		Donut	Bagel
0mm			
210mm	100%	3,000Ltr.	5,000Ltr.
322.5mm	75%	2,250Ltr.	3,750Ltr.
645mm	50%	1,500Ltr.	2,500Ltr.
864.3mm	33%	1,000Ltr.	1,667Ltr.
967.5mm	25%	750Ltr.	1,250Ltr.
1161mm	10%	300Ltr.	500Ltr.
1300mm	0%	0	0

Step by Step Instructions

Step 1

Excavate hole to dimensions refer to page six.

Step 2

Prepare base of hole with backfill material refer to page eight.

Step 3

Attach barrel filter unit, refer to page four. If required position adjustable collar. Note: Silicone must be used between the joint of tank inlet, the barrel filter unit & collar to form a water tight seal.

Step 4

Lift tank into hole using lifting lugs on top of tank.

Step 5

Fill around perimeter of tank with backfill material, refer to page eight.

Step 6

Fill centre of tank up to 150mm below the tank's half way flange with backfill material.

Step 7

Fill centre of tank with backfill material and/or concrete ballast. Refer to page eight for details on correct backfill and / or concrete ballast required by soil type. It is critical that all the nominated ballast be used on the tank's upper and perimeter surface, excluding the inspection lid opening.

Step 8

Tank is now ready to be covered and landscaped over.

Step 9

The best looking tank you'll never see!

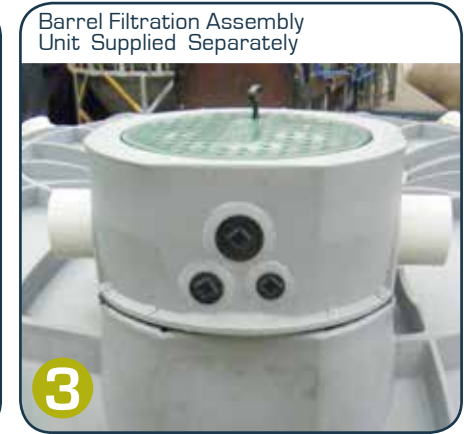

Viscount Rotational Mouldings Pty Ltd shall not accept liability of any kind arising out of misuse of the product or use for any other purpose than its intended use as contained herein. All information supplied in this brochure was correct at time of printing. Viscount Rotational Mouldings Pty Ltd reserves the right to change specifications, colours and designs without further notice. Effective 31.07.2012.



Viscount Rotational Mouldings Pty Ltd

ABN: 19067462337

81 Frankston Gardens Drive
Carrum Downs, Victoria, 3201, Australia.

Tel: (03) 8770 3200

Fax: (03) 8770 3204

Sales Enquiries: 1800 775 000

Web VRM: www.viscountroto.com.au



Australian Standard
AS/NZS 4766
Lic 21597



Australian Standard
AS/NZS 1546.1
Lic 20051



Quality Endorsed Company
ISO 9001 Lic 22114
SAI Global