

HORIZONTAL MULTI STAGE PUMP SYSTEMS



HCM2-40

HCM2-60

HCM4-60

HCM Series Horizontal Multistage Pumps are a must for higher pressure applications with a quiet and reliable operation. They come with a tough construction, IP 55 rated motors and stainless steel chambers, impellers and motor shaft. The HCM series are AS4020 Certified for potable water applications and are available in 4 – 6 stage models making them ideal for pumping water in residential, commercial and industrial applications.

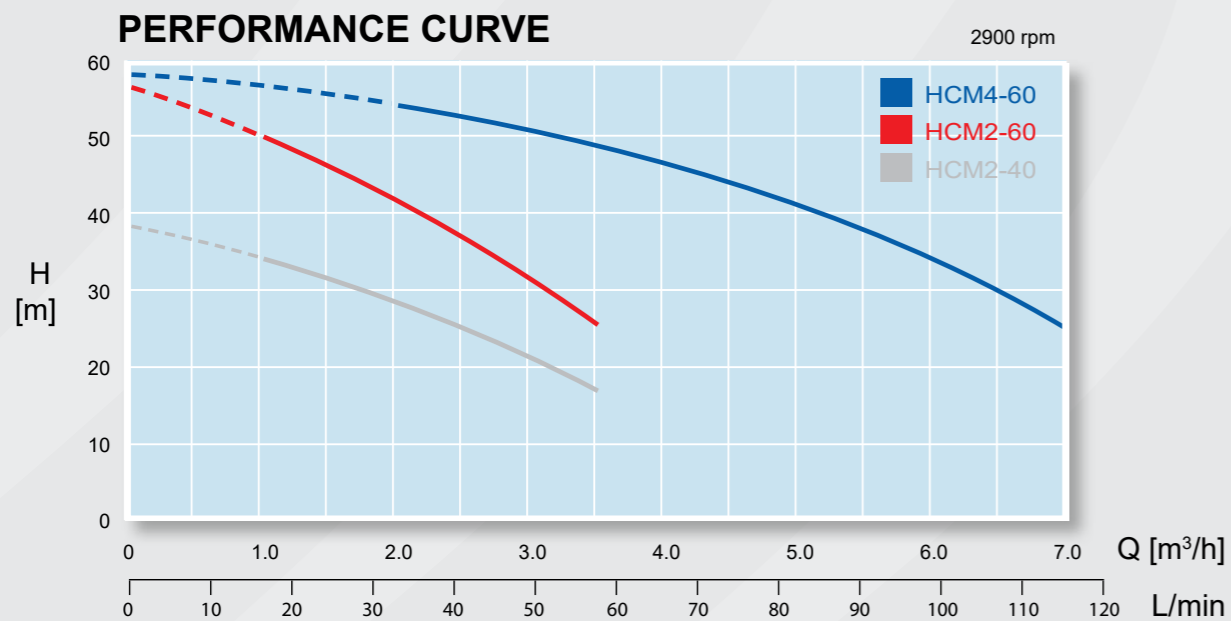

HCM2-40 | HCM2-60 | HCM4-60

APPLICATION

- Household water supply & irrigation
- Rainwater tank pumpset
- Water transfer
- Pressure boosting

FEATURES

- Automatic pressure controller
- Run dry protection
- Quiet operation

CONSTRUCTION

- Stainless steel impellers, chambers & shaft
- NBR carbon / ceramic mechanical seal
- IP55 motor
- Insulation class F
- Heavy duty brass coupling

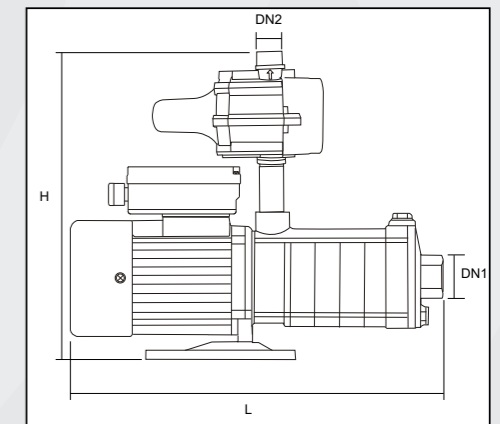

DIMENSIONS

Pump Model	Size (mm)		DN1	DN2	G.W (KG)
	H	L			
HCM2-40	385	360	25F	25M	13.7
HCM2-60	385	395	25F	25M	15.1
HCM4-60	380	443	32F	25M	17

TECHNICAL DATA

Pump Model	Power (P2) (kW)	Amps (A)	Max. FLOW (L/min)	Max. HEAD (m)	Inlet/Outlet	Water Temp
HCM2-40	0.55	4.2	58	38	1" x 1"	0-70°C
HCM2-60	0.75	5.2	58	56	1" x 1"	0-70°C
HCM4-60	1.1	6.8	116	58	1 1/4" x 1"	0-70°C