

TOP MULTI-TECH

Multi-stage automatic submersible pumps

-  Clean water
-  Domestic use
-  Civil use

**AUTOMATIC
START & STOP**



PERFORMANCE RANGE

- Flow rate up to **120 l/min** (7.2 m³/h)
- Head up to **42 m**
- Restart pressure: **1.5 bar**

APPLICATION LIMITS

- **5 m** maximum immersion depth
- Maximum height between pump and point of use **10 m**
- Maximum liquid temperature **+40 °C**
- Suction down to **34 mm** above ground level
- Continuous service **S1**

CONSTRUCTION AND SAFETY STANDARDS

Complete with:

- **10 m** long power cable
- internal electronic device for pump starting (when tap opened) and stopping (when tap closed)
- threaded connector 1¼" (delivery)
- hose connector Ø 35 mm

EN 60335-1
IEC 60335-1
CEI 61-150

EN 60034-1
IEC 60034-1
CEI 2-3



CERTIFICATIONS

Company with management system certified DNV
ISO 9001: QUALITY



INSTALLATION AND USE

TOP-MULTI-TECH pumps are recommended for pumping **clean water** and liquids that are not chemically aggressive for the materials from which the pump is made.

Because of their high efficiency and reliability they are suitable for use in applications such as domestic water supply from reservoirs, tanks or relatively deep wells, for drawing rain water from cisterns to water gardens or for use in irrigation systems, etc.

An internal electronic device starts or stops the pump automatically when the tap is opened or closed.

PATENTS - TRADE MARKS - MODELS

- Patent n. EP2990653
- TOP MULTI® Registered Trade Mark n. 0001334477

OPTIONS AVAILABLE ON REQUEST

- Other voltages or 60 Hz frequency

CHARACTERISTIC CURVES AND PERFORMANCE DATA

50 Hz n= 2900 min⁻¹

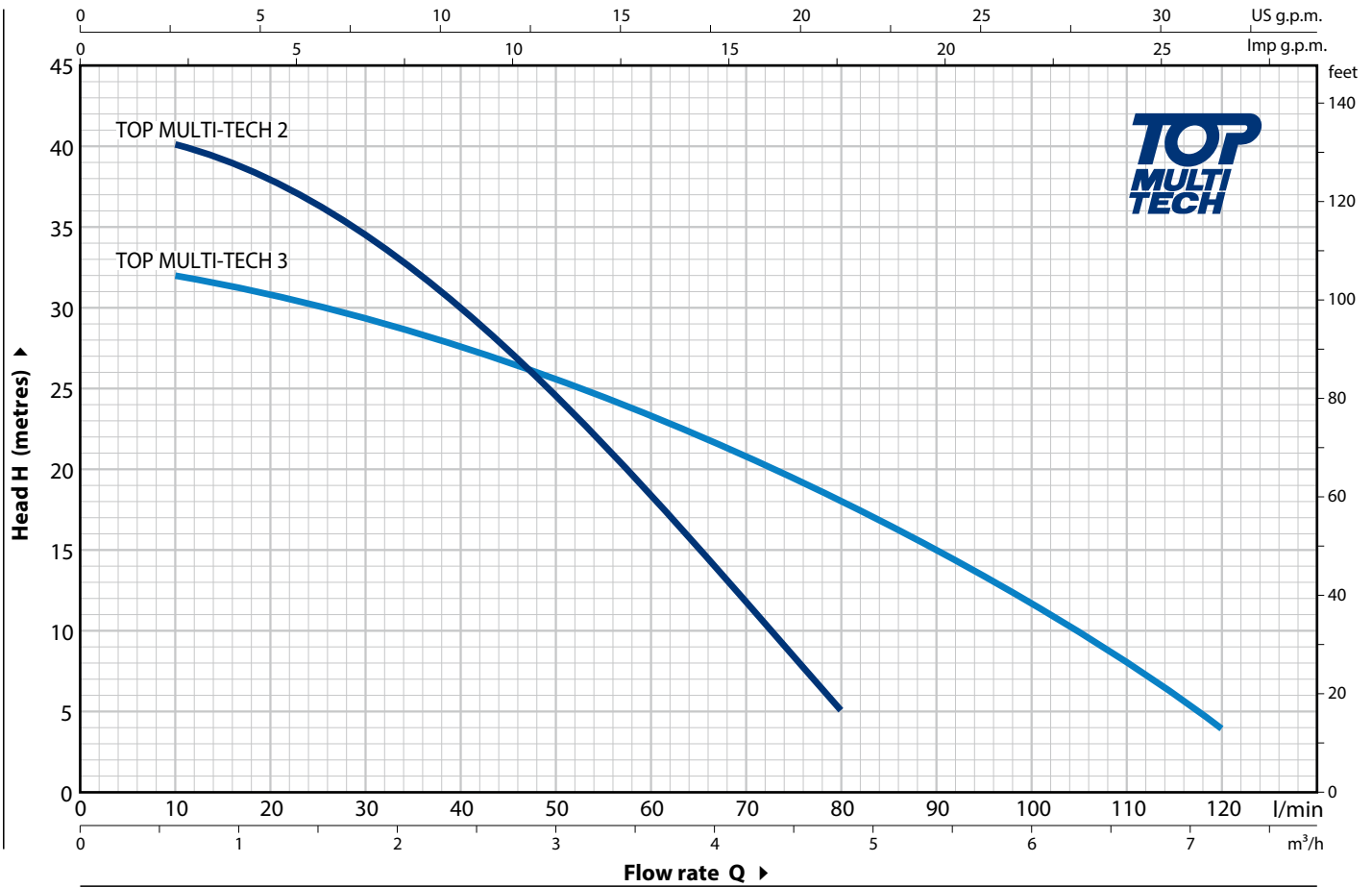

MODEL Single-phase	POWER (P ₂)		Q	0	0.6	1.2	1.8	2.4	3.0	3.6	4.2	4.8	5.4	6.0	6.6	7.2
	kW	HP		0	10	20	30	40	50	60	70	80	90	100	110	120
TOP MULTI-TECH 2	0.55	0.75	H metres	42	40	38	34	30	24	18	11.5	5				
TOP MULTI-TECH 3	0.55	0.75		33	32	31	29.5	28	25.5	23	20.5	18	15	12	8	4

Q = Flow rate H = Total manometric head

Tolerance of characteristic curves in compliance with EN ISO 9906 Grade 3B.

 = Stocked in Australia

Other models available upon request with 6 to 8 weeks lead time.

TOP MULTI-TECH

POS. COMPONENT

CONSTRUCTION CHARACTERISTICS

1	DELIVERY BODY	Glass fibre reinforced technopolymer
2	PUMP BODY E SUCTION FILTER	Glass fibre reinforced technopolymer
3	DIFFUSER	Glass fibre reinforced technopolymer
4	MOTOR SLEEVE	Stainless steel AISI 304
5	IMPELLERS	Noryl FE1520PW
6	DIFFUSER AND STAGE BOXES	Noryl complete with anti-wear ring
7	MOTOR SHAFT	Stainless steel AISI 431
8	ELECTRONIC DEVICE	<p>TOP MULTI-TECH pumps are fitted with an internal electronic device which starts the pump when the pressure of the system falls below 1.5 bar (eg. when opening a tap) and stops it when the flow falls below 3 litre per minute.</p> <p>It protects the pump:</p> <ul style="list-style-type: none"> – against dry running; – against blockage: after long periods of pump inactivity the electronic device starts the pump every 48 hours for 10 seconds.

9 TWO MECHANICAL SEALS SEPARATED BY AN OIL CHAMBER

<i>Seal Model</i>	<i>Shaft Diameter</i>	<i>Position</i>	<i>Materials</i>		
			<i>Stationary ring</i>	<i>Rotational ring</i>	<i>Elastomer</i>
STA-13R	Ø 13 mm	Motor side	Ceramic	Graphite	NBR
STA-12R SG	Ø 12 mm	Pump side	Silicon carbide	Graphite	NBR

10 BEARINGS

6202 ZZ - C3 / 6201 ZZ

11 CAPACITOR

Capacitance

(230 V or 240 V)

12.5 µF 450 VL

(110 V)

30 µF 250 VL

12 ELECTRIC MOTOR

TOP MULTI-TECH: single-phase 230 V - 50 Hz with thermal overload protector incorporated into the winding.

- Insulation: class F
- Protection: IP X8

13 POWER CABLE

"H07 RN-F" with Schuko plug

Standard length 10 metres

14 THREADED CONNECTOR

Threaded connector 1¼"

15 HOSE CONNECTOR WITH RING NUT

Ø 35 mm hose connection

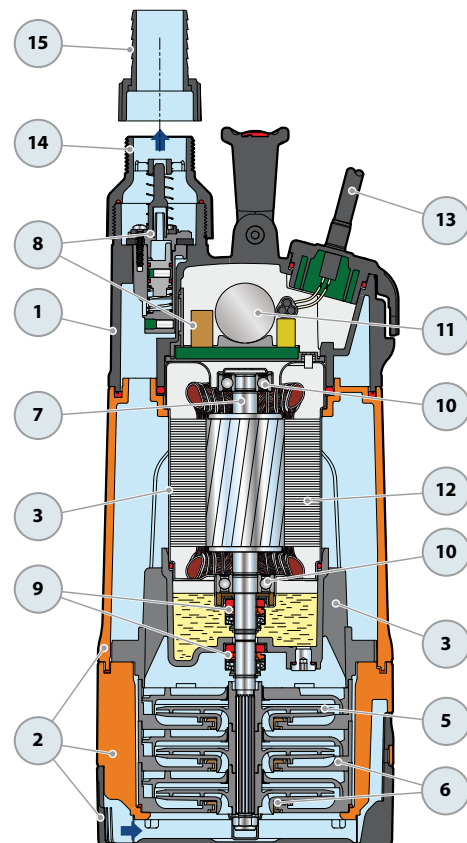

DIMENSIONS AND WEIGHT

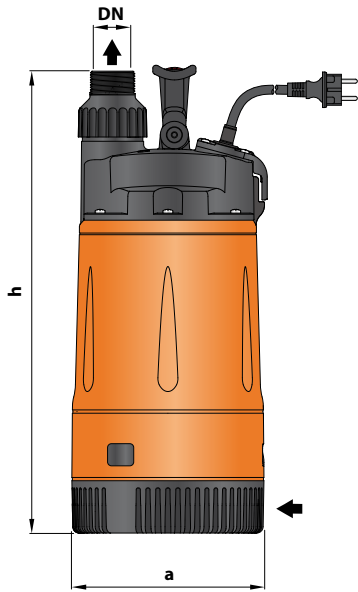

MODEL	PORT	N. STAGES	DIMENSIONS mm		kg
Single-phase	DN		a	h	
TOP MULTI-TECH 2	1 1/4"	3	178	428	9.3
TOP MULTI-TECH 3					



ABSORPTION

MODEL	VOLTAGE
Single-phase	230 V
TOP MULTI-TECH 2	3.4 A
TOP MULTI-TECH 3	3.6 A

PALLETIZATION

MODEL	GROUPAGE	CONTAINER
Single-phase	n. pumps	n. pumps
TOP MULTI-TECH 2	60	80
TOP MULTI-TECH 3	60	80

ACCESSORIES (CAN BE ORDERED SEPARATELY)

MODEL	Code	FITTING	CAPACITY	PRE-SET	MAXIMUM WORKING PRESSURE
Tank 1 SF 	500667	1/2" (male)	1 litre	1.2 bar	10 bar
3-way fitting NT 1.25 	500160001	1 1/4" - 1/4" - 1/2" gas	-	-	-

Standard installation

