

WATER SUPPLY & PRESSURE PUMPS

Jet Pumps

HSJ SERIES

HSJ370



HSJ550



HSJ Series are horizontal, stainless steel self-priming jet pumps, ideal for pumping clear water and other non-aggressive liquids. HSJ Series have a tough construction, with a stainless steel shaft and impeller, and IP 55 rated motors. Also having an AS4020 potable water certificate which makes the HSJ series compatible for household water supply applications. There are 4 models available which make choosing the right pump for a reliable water supply easy.

PERFORMANCE

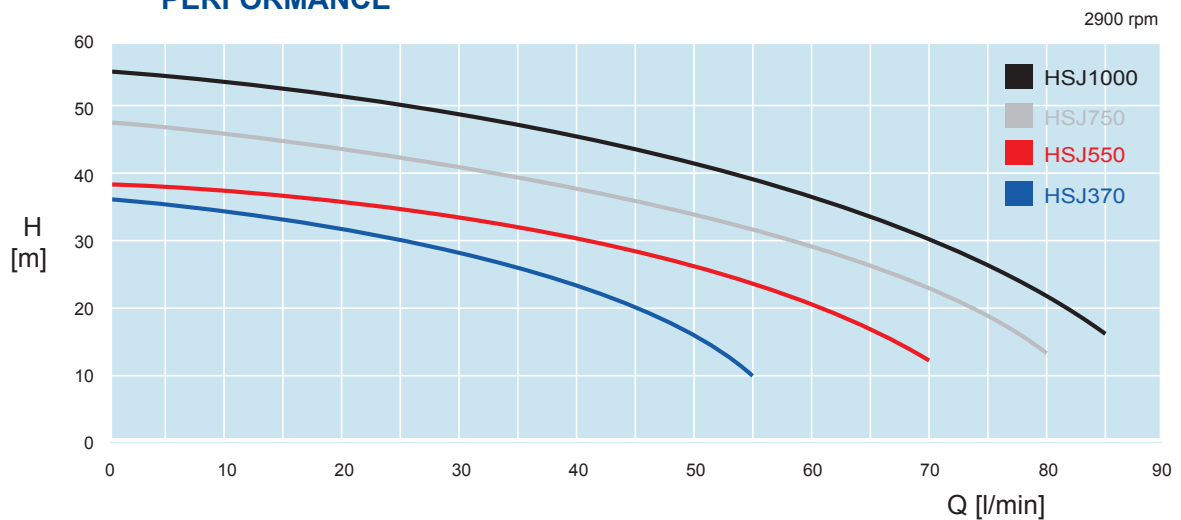



HSJ750



HSJ1000



APPLICATION

- Household water supply and irrigation
- Rainwater tank pump set
- Water transfer
- Pressure boosting
- Pumping from underground tanks

FEATURES

- Automatic pressure controller (Start & Stop on demand)
- Run dry protection
- Quick plug electrical connection for pressure controller
- Efficient on power consumption

CONSTRUCTION

- Pump body: AISI 304 Stainless steel
- Impeller: Stainless steel
- Motor shaft: Stainless steel
- Mechanical seal: Ceramic / Graphite / NBR
- IP55 motor
- Insulation class F
- Heavy duty brass coupling

DIMENSIONS

Pump Model	Size (mm)		DN1	DN2	G.W (KG)
	H	L			
HSJ370	370	365	25F	25M	8.6
HSJ550	400	355	25F	25M	10.6
HSJ750	400	355	25F	25M	10.7
HSJ1000	410	415	25F	25M	14

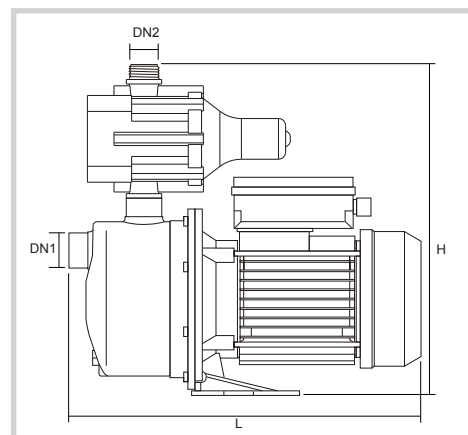

TECHNICAL DATA

Pump Model	Power (kW)	Power (HP)	Max. FLOW (L/min)	Max. HEAD (m)	Max. SUCT (m)	Voltage (V)	Inlet/Outlet (mm)
HSJ370	0.37	0.50	55	36	8	220-240	1"x1"
HSJ550	0.55	0.75	70	38	8	220-240	1"x1"
HSJ750	0.75	1	80	45	8	220-240	1"x1"
HSJ1000	1.00	1.5	85	52	8	220-240	1"x1"