

ITEM NO.	PRODUCT CODE	DESCRIPTION	QTY.
1	RWT9000	9000L RAIN WATER TANK	1
2	OFF9	OVERFLOW PVC FLANGED 90MM	1
3	S4	400mm LEAF STRAINER	1
4	LHO1.5	40mm [1.5"] BRASS BSP TANK OUTLET	1
5	BV1.5L	40mm [1.5"] BALL VALVE - BRASS	1

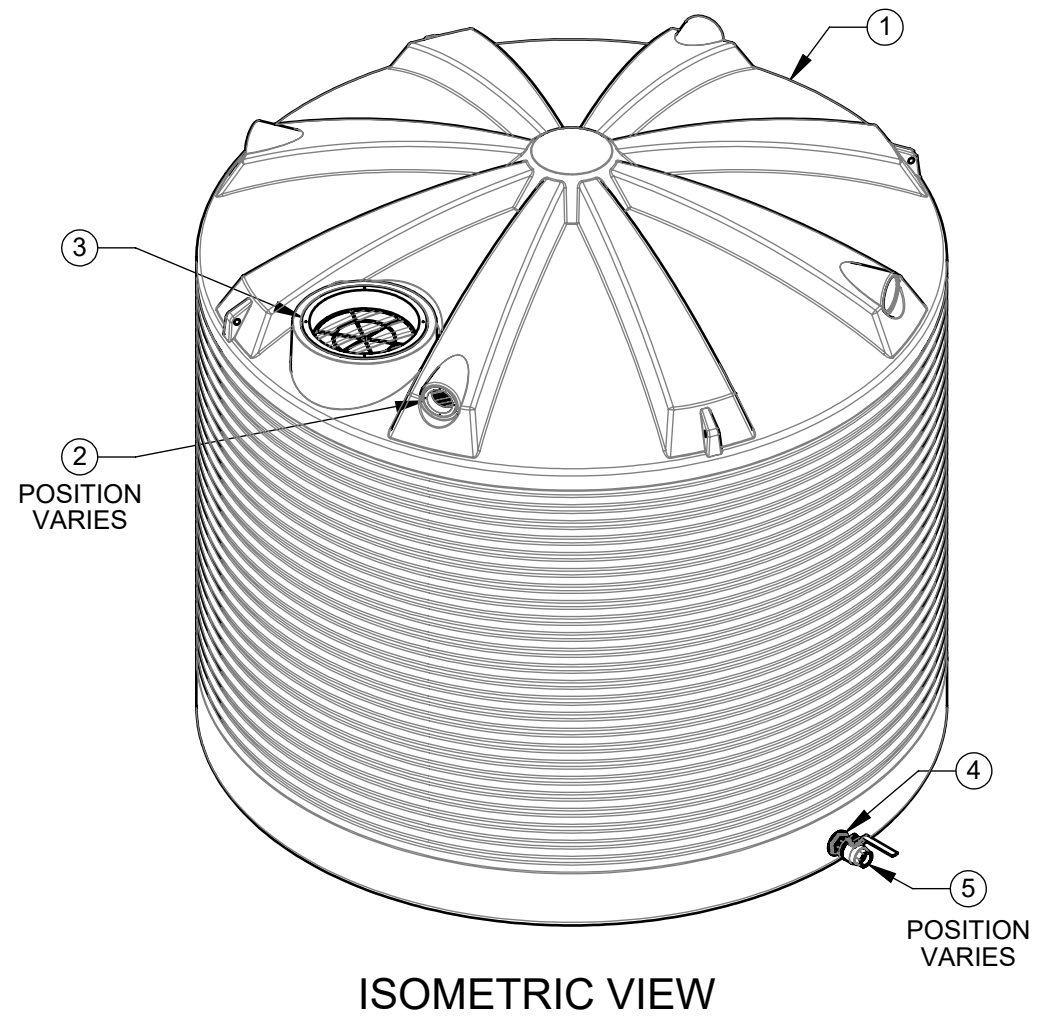
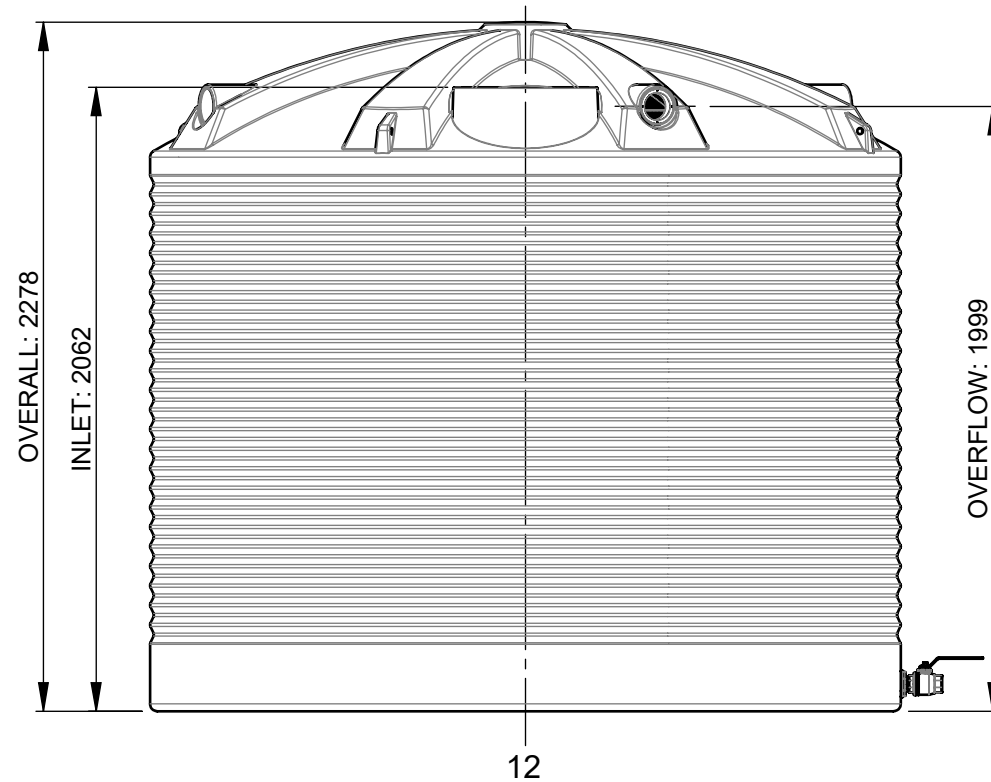
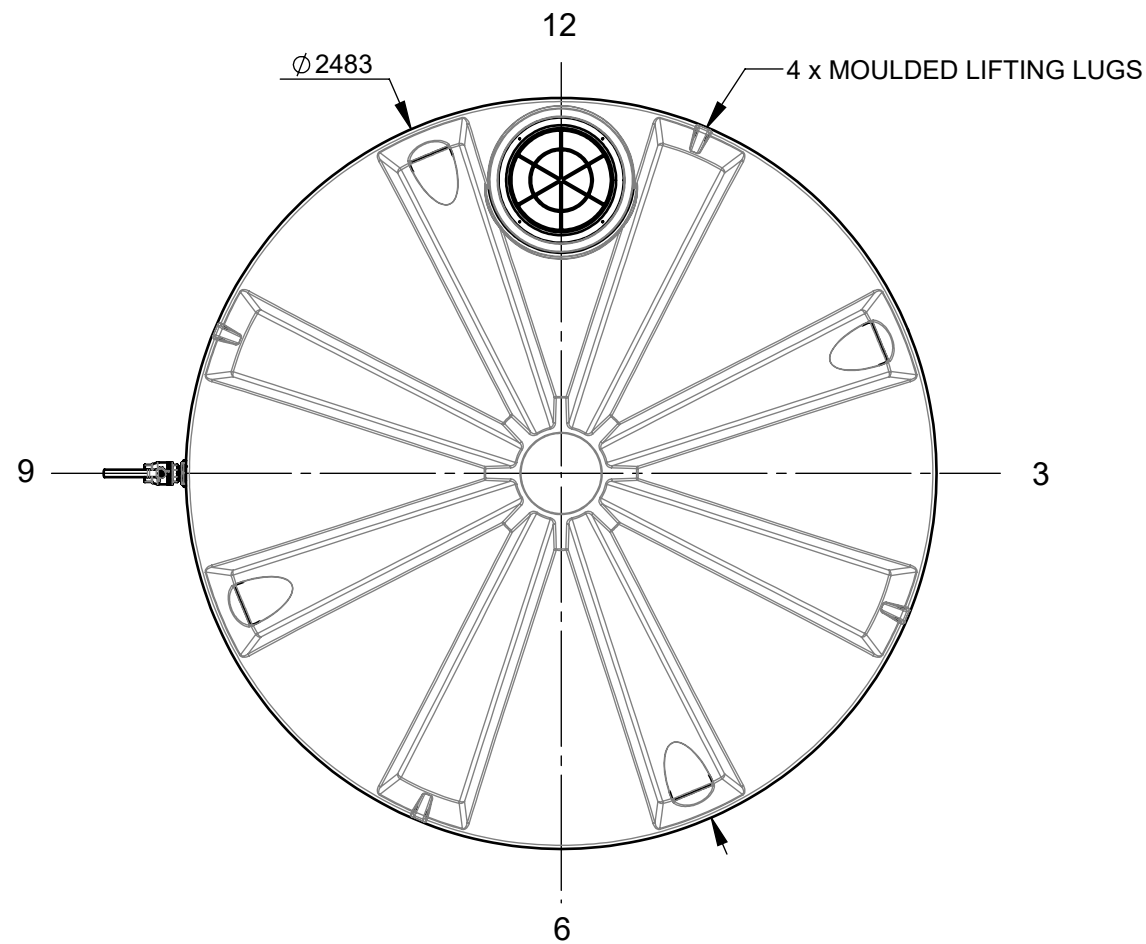

NOTE:
DUE TO SHRINKAGE VARIATIONS IN MANUFACTURE,
ALL MEASUREMENTS ARE APPROXIMATE ONLY.

NOTE: ALL TOLERANCES UNLESS OTHERWISE STATED $\pm 10\text{mm} / \pm 1^\circ$
DO NOT SCALE, USE DIMENSIONS. ALL DIMENSIONS ARE IN mm
This drawing is the property of Polymaster Group Pty. Ltd. It cannot be copied
in part or in full without the written permission of Polymaster Group Pty. Ltd.

© POLYMASTER GROUP



161 KARINIE STREET
SWAN HILL. VIC.
3585
Ph: (03) 5033 9000
Fx: (03) 5033 0224

DESCRIPTION	9000L RAIN WATER TANK	A3 SHEET SIZE	SCALE: 1:25
PRODUCT CODE	RWT9000		
MATERIAL		DRAWN	MV
COLOUR			
DRAWING No.	RWT9000 GA	28/06/22	1/1
Rev:	A		