

RAIN HARVESTING

by Blue Mountain Co

Triple Action Filtration System (Slim)



Installation and Specification Guide

PRODUCT DETAILS

This single stage filter includes a carbon block filter which removes fine sediment down to 10 microns in size, and reduces colour, odour, and chlorine in your water.

The slimline design is perfect for tight spots and smaller dwellings when used for whole house filtration, or large dwellings also, when used for partial water supply.

Code	Size	Country
WFRW11	10in	Global
WFRW12	20in	
WFRW111	10in	USA
WFRW112	20in	

Installation

WHAT'S IN THE BOX?

- Filter Housing
- Filter Cartridge
 - Triple Action GAC Filter Cartridge
- Housing Ring Spanner
- Wall bracket & screws

TOOLS/MATERIALS YOU MAY REQUIRE

- Tape measure
- Marker pen
- Pipe cutters
- Deburring tool
- PTFE (Teflon thread tape)
- 2 Threaded adaptors
(Isolation valve and refer to installation layout and existing pipework for further information.)
- Adjustable wrench
- Screw driver
- Drill

CAUTION: Do not use with water that is microbiologically unsafe or with water of unknown quality without adequate disinfection before or after the system. Systems certified for cyst reduction may be used on disinfected water that may contain filterable cysts. If not properly maintained, the use of this system may increase the bacterial content of the water unless supplementary treatment is provided.

GENERAL REQUIREMENTS

- Installation must be made in accordance with the Plumbing Code of Australia (PCA) by a licensed plumber only.
- Observe the use limits indicated on the filter label.
- If pressure exceeds use limits, protect with a pressure reducer.
- Install an "anti-water hammer" system to protect the filter.
- Keep away from light sources.
- Keep away from excessive heat and cold (min. 4°C, max 45°C).
- Only use original Blue Mountain Co cartridges.
- The use of non-original cartridges may void the warranty.

INSTALLATION

- Before the installation, carefully lubricate the housing o-ring which is located at the bowl top.
- Before the installation, check if the hydraulic system has been set-up according to local authority guidelines.
- Install the products in sheltered areas and protect from freezing and excessive heat.
- Please refer to Installation Layout to check the correct location of isolating valves and pressure control devices.
- The installation of any backflow prevention device must be in accordance with the Plumbing Code of Australia (PCA) and AS/NZS 3500.1 and comply with AS 2845.1:2010. Please refer to Installation Layout section: a dual check valve is recommended; a single check valve or non-return valve is not acceptable.
- Internal water pressure in buildings should be limited to a maximum of 500 kPa (0.5 bar). The recommended pressure reducer must be WaterMarked and/or compliant with AS/NZS 3500.1 and installed in accordance with the Plumbing Code of Australia (PCA).

WARNING: Water pressure above 500 kPa may damage connected products including water filters and will void the product warranty.

IN-OUT directions and vent-valve (VV) location in different models.

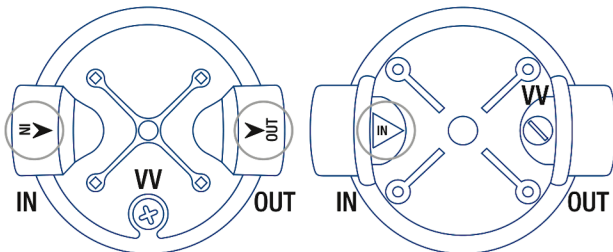

Only use PTFE thread seal tape to seal filter connections. Using other types of sealing material may void the warranty.

Installation layout

- 1 - Water mains
- 2 - Dual check valve
- 3 - Pressure reducer
- 4 - By-pass (optional or check local authority guidelines)
- 5 - Anti-water hammer device (expansion vessel)
- 6 - Filtering unit of any model
- 7 - Isolating Valve
- 8 - Other Utilities

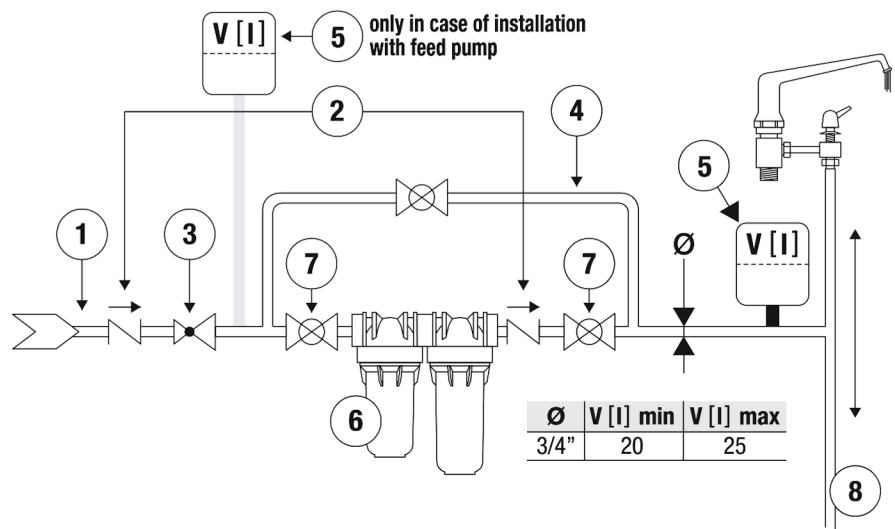

INSTALLATION START-UP AND FIRST USE

- 1 - Turn-off water mains.
- 2 - Avoid all kind of tensions by using original wall brackets as a support
- 3 - The installation of a by-pass is recommended.
- 4 - Connect the inlet to the product's side with the indication IN and the outlet to the side with the indication OUT.
- 5 - Connect to pipes using cylindrical (parallel) fittings or US - conical (tapered) fittings, possibly with flexible hoses.
- 6 - Use only sealing tape as a sealant for the connections.
- 7 - If the product is supplied without cartridge/s, unscrew the housing bowl from head and insert the cartridge/s, lubricate the o-ring, then screw the bowl to head and tighten with original spanners.
- 8 - Turn on water mains.
- 9 - Unscrew the vent-valve and wait for air purge, then screw and tighten the vent-valve. After installation, slowly turn on a water supply (tap) downstream the installed unit and let the water flow for at least 5 minutes to flush the system before use.

WARNING: Make sure that there are no water leaks from the product, ensure you control the tightening between the housing head and the housing bowl. Continue checking that the tightening is good and there is no water leakage for 48 hours following the Installation and start-up. In case of leakage, open the housing, remove the o-ring from the bowl, place a new o-ring and apply lubricant, then re-tighten the bowl to head and repeat the leakage check as above.

WARNING: For correct operation of this appliance, it is essential to observe the manufacturer's instruction.

Product Specifications

Triple Action Filtration System (Slim)

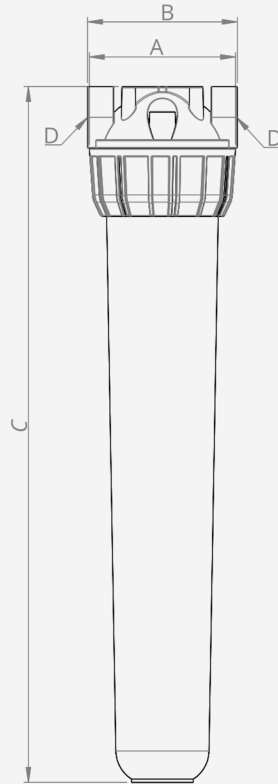

Country	Code	A	B	C	D
Global	WFRW11	130	133	315	3/4" BSP
	WFRW12	130	133	617	3/4" BSP
USA	WFRW111	5.12"	5.24"	12.4"	3/4" NPT
	WFRW112	5.12"	5.24"	24.29"	3/4" NPT

All dimensions are in mm unless otherwise stated.

Filter Housing

TEMPERATURE RANGE	WORKING PRESSURE	MAX FLOW	IN/OUT
4 to 45°C	50kPa (7.25psi/0.5bar) to 830kPa (120psi/8.3bar)	83 litres/min*	3/4" Brass BSP (20mm) US - 3/4" Plastic NPT

*Flow rate will depend on cartridge selection, supply pipe pressure and size.

Thread Type

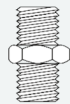

BSP parallel
(cylindrical)

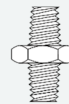

NPT tapered
(conical) - US

Included cartridge

Triple Action GAC Filter Cartridge

TEMPERATURE RANGE	MICRON RATING	MATERIAL	REDUCES	AVERAGE LIFE-SPAN
4 to 45°C	10 micron (nominal)	Wound polypropylene thread and granular activated carbon (GAC)	Fine sediment, taste, colour, odour and chlorine.	3 months

Filter Cartridge Replacement

- 1 - Before opening the housing turn-off water mains.
- 2 - Release the pressure from the product by un-screwing the vent-valve.
- 3 - Open the housing unscrewing the bowl from head.
- 4 - Remove the used cartridge.
- 5 - Wipe clean the filter housing with cold water and a soft sponge.
- 6 - Open the new cartridge wrap and discard wrap. Carefully read the leaflet/sticker for directions and keep it for future reference.
- 7 - Insert the new cartridge and place it into the housing.
- 8 - Lubricate the o-ring with lubricant or change with a new o-ring.
- 9 - Tighten the housing bowl to the housing head using original spanners. Do not over-tighten.
- 10 - Turn on water mains.
- 11 - Wait for air purge from the vent-valve, then screw and tighten the vent-valve.
- 12 - Slowly turn on water supply (tap) downstream of the installed unit and let the water flow for at least 5 minutes to flush the system before use.

Maintenance

- Periodically clean the housing with cold water and a soft sponge.
- Flush system for 10 minutes after any period of non-use more than two days. For a period of non-use of two weeks or more, it may be necessary to replace the cartridge.
- Replace the cartridge after 3 months or when a drop in downstream water pressure is observed.



A common misconception about collecting rainwater is that all you need is a roof, a tank and some rain. This 'tanking' approach cannot always be relied on to deliver the volume – or quality – of water that you require. That is where we can help.

With some thought, your rain harvesting system can provide you with cleaner water and lots of it. Whether you're completely reliant on tank water or wanting to keep the garden green, our simple steps will help you achieve your goal.

The Rain Harvesting approach to rainwater collection involves using tested and proven products to make quality rainwater available for use in and around your property. You don't need much to get started and you will be surprised how easy it is to get the most out of your rainwater system.

[How can we help you?](#)

WARRANTY INFORMATION

Blue Mountain Co guarantees this product for 12 months from date of purchase.

Under this warranty we will replace the product or repair it free of charge. Claims must be received by Blue Mountain Co (info@bluemountainco.com.au) within 12 months of the date of purchase. The benefits conferred by this warranty are in addition to all other rights and remedies available in law in respect to the goods and services to which it relates. Our goods come with guarantees that can not be excluded under the Australian Consumer Law.

You are entitled to a replacement or refund for a major failure and for compensation for any other reasonable foreseeable loss or damage. You are also entitled to have the goods repaired or replaced if the goods fail to be of acceptable quality and the failure does not amount to a major failure.

DISCLAIMER This product specification is not a complete guide to product usage. Further information is available from Rain Harvesting Pty Ltd and from the Installation and Operating Instructions. This specification sheet must be read in conjunction with the Installation and Operating Instructions and all applicable statutory requirement. Product specifications may change without notice. © Rain Harvesting Pty Ltd

RAIN HARVESTING

by Blue Mountain Co

For more information or to find out
how we can help, just give us a call on

+61 7 3248 9600

Or visit our website at

rainharvesting.com