

Li-Lo 1500 L / 396 gal.

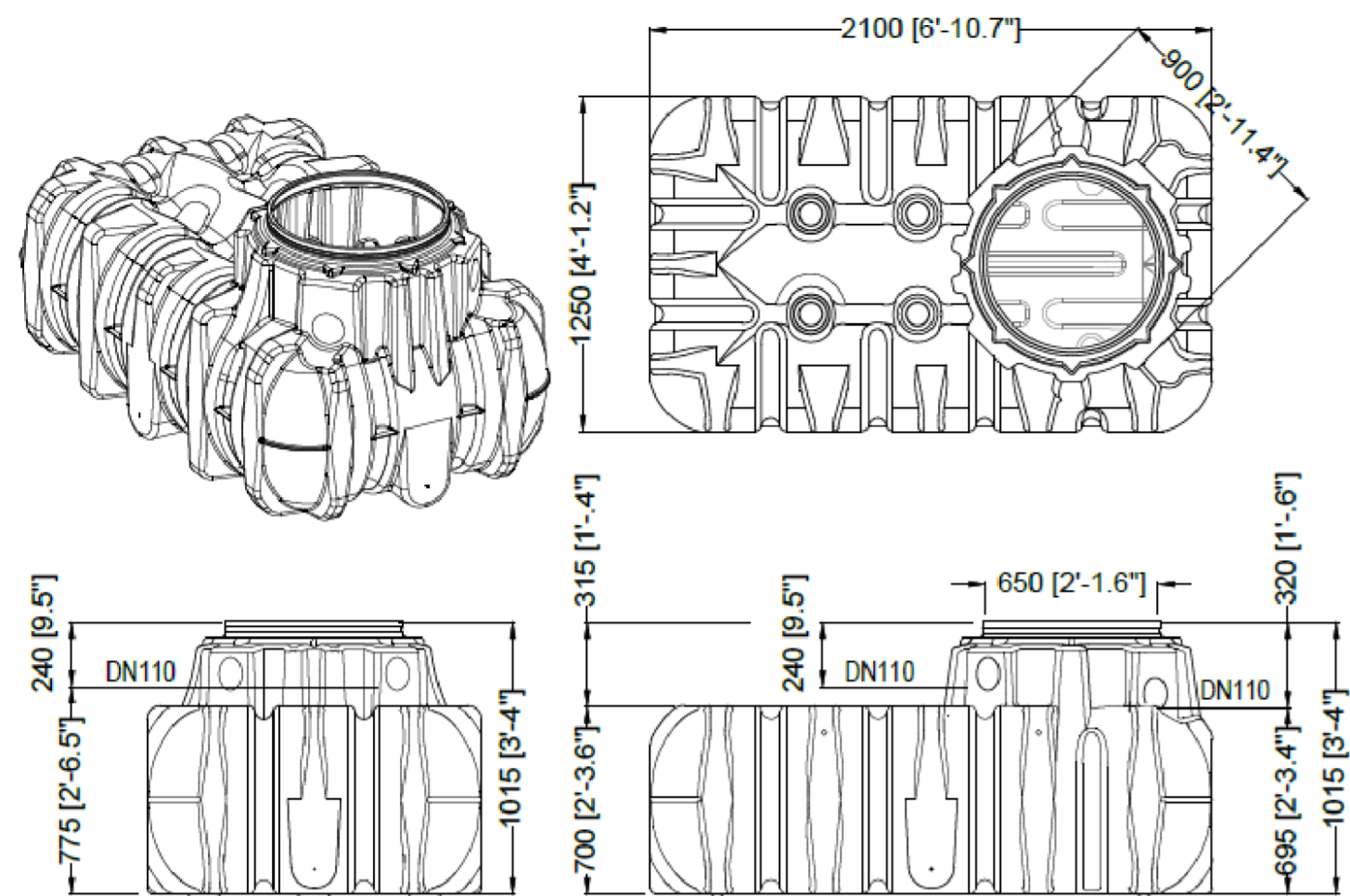

Li-Lo 3000 L / 792.5 gal.

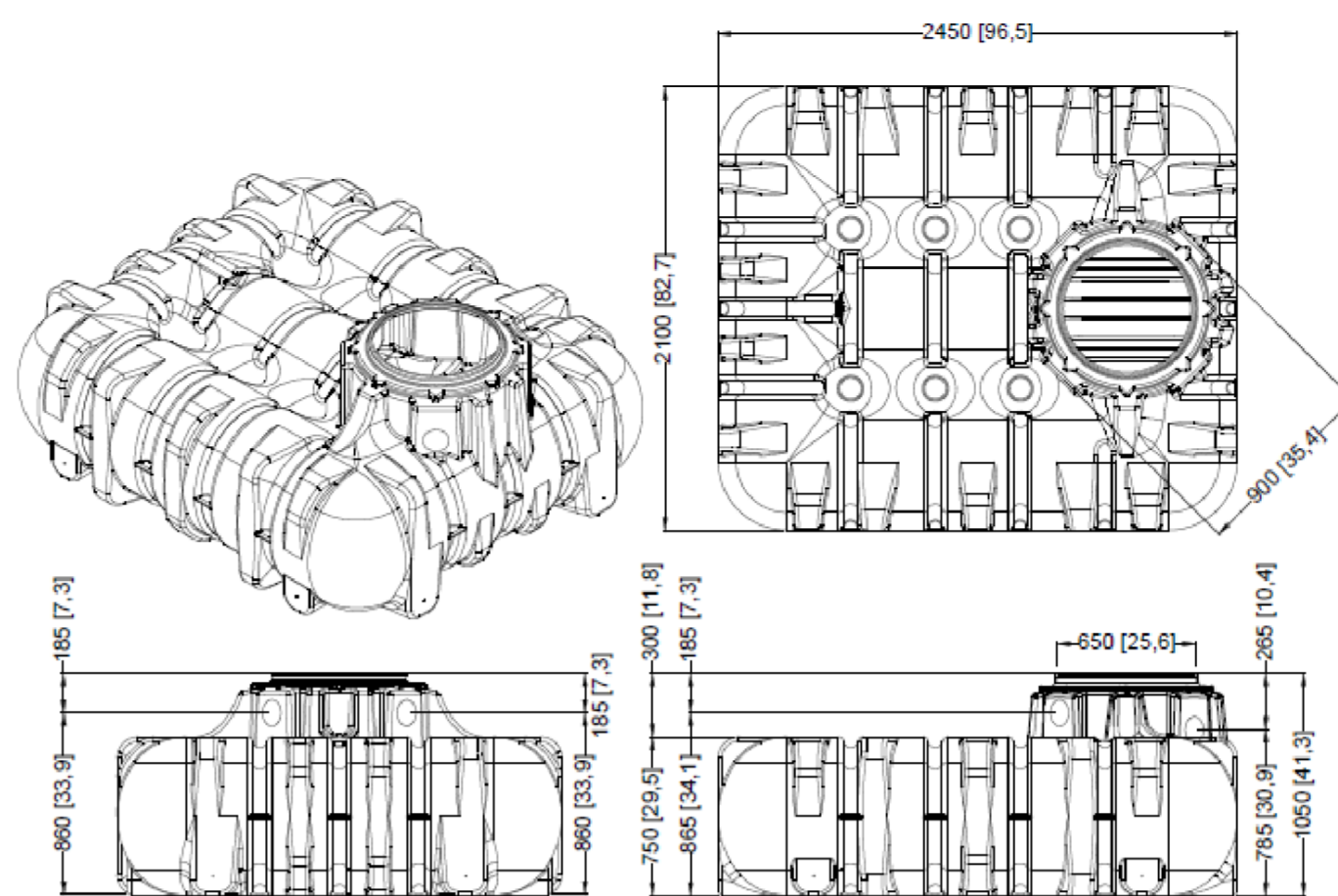

Li-Lo 5000 L / 1320.9 gal.

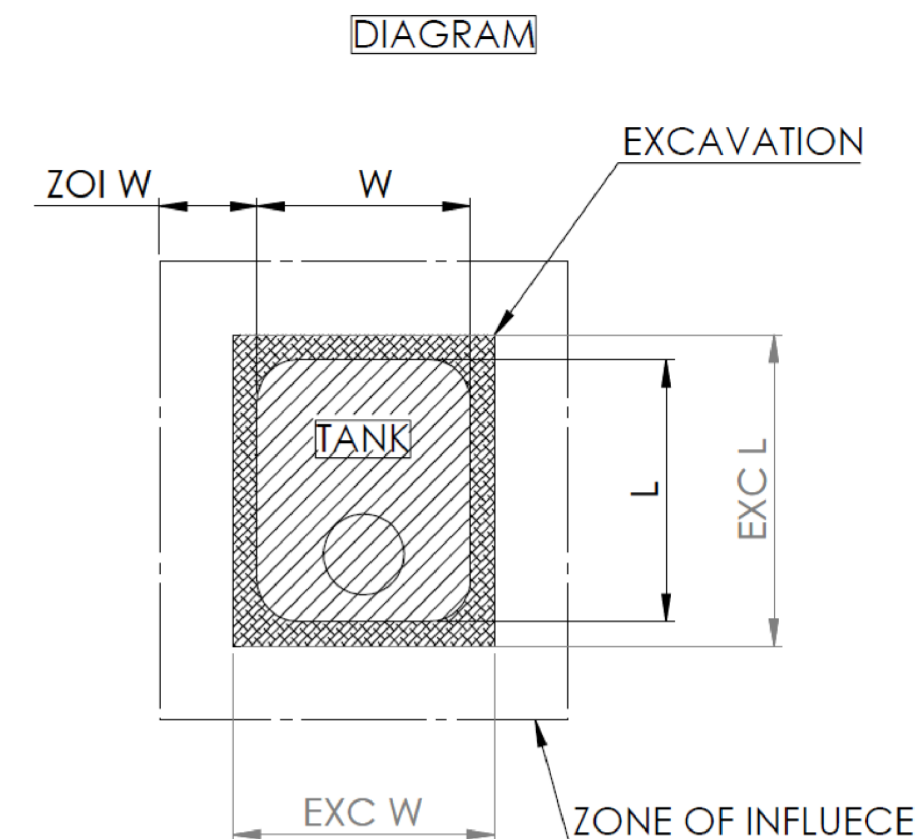
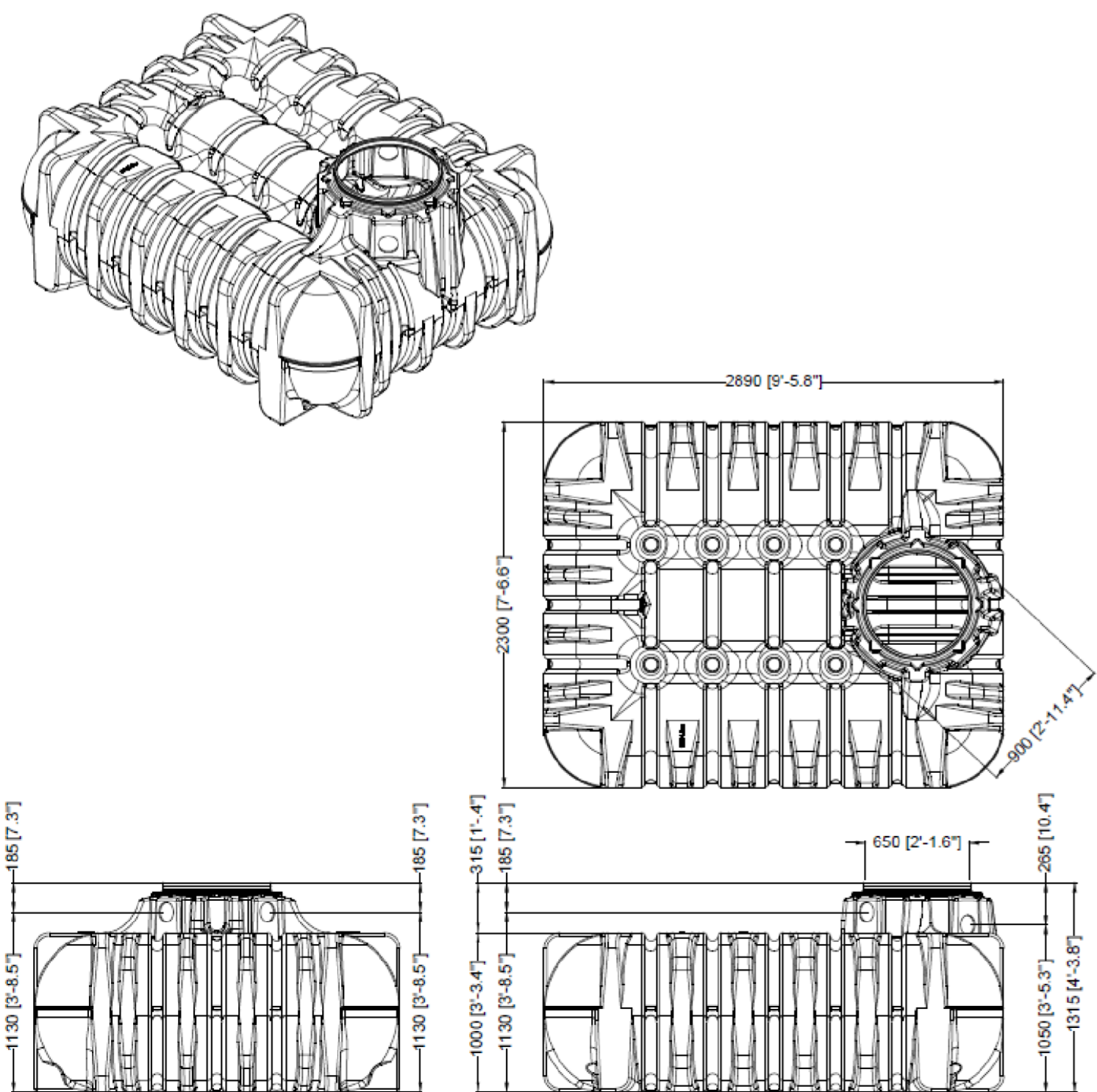

TANK MODEL	CAPACITY [litres]	DIMENSIONS LxWxH [mm]	ZONE OF INFLUENCE** [mm]	EXCAVATION SIZE LxWxD [mm]
LiLo 1500L	1500	2100x1250x1015	1100 around the tank	2700x1850xD*
LiLo 3000L	3000	2450x2100x1050	1135 around the tank	3050x1650xD*
LiLo 5000L	5000	2890x2300x1315	1400 around the tank	3490x1910xD*

\* EXCAVATION DEPTH DEPENDS ON THE CHOSEN TANK CONFIGURATION, REFER TO GENERAL EARTH COVERAGE REQUIREMENTS BELOW. THE EXCAVATION DEPTH MUST BE ESTABLISHED ON A CASE TO CASE BASIS, CONTACT KINGSPAN FOR ASSISTANCE.

\*\* ZOI AREA IS CONDITIONALLY CALCULATED ON THE MINIMUM PRODUCT EXCAVATION DEPT, NUMBER STATED IS CONSIDERED A MINIMUM REQUIREMENT AND EXCLUDES RISER HEIGHT ADJUSTMENTS. FINAL ZOI AREA TO BE THE RESPONSIBILITY OF THE SPECIFYING ENGINEER

